

# REMOTE CONTROLLED DOG TRAINING COLLARS

OWNER'S MANUAL



## **Dogtra Company**

1250 E. 223rd Street, Suite 119  
Carson, CA 90745

Tel : (310) 522 - 1800

Fax : (310) 522 - 1805

Toll Free : 1-888-811-9111

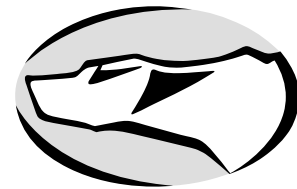

## ***dogtra* 175 NCP**



## CONTENTS

---

- MAIN FEATURES ..... 2
- PRODUCT SAFETY AND HEALTH STATEMENTS ..... 3
- **dogtra** COLLAR PACKAGE CONTENTS ..... 5
- DESCRIPTION OF TRANSMITTER PARTS ..... 6
- DESCRIPTION OF COLLAR / RECEIVER PARTS .... 13
- BATTERY CHARGER ..... 18
- CHARGING THE BATTERIES ..... 19
- TESTING YOUR **dogtra 175 NCP** COLLAR .... 22
- OPERATING INSTRUCTIONS ..... 24
- ACCESSORIES ..... 28
- WARRANTY AND REPAIR INFORMATION ..... 29

### MAIN FEATURES

- Easy-to-use, ergonomic transmitter.
- Rheostat dial that allows for gradual increases in stimulation intensity with no jumps between levels.
- The **dogtra 175NCP** has a range of 400+ yards.
- Waterproof collar/receiver and water-resistant transmitter.
- No external antenna on the collar receiver.
- Rechargeable, user-replaceable Ni-MH batteries.
- One-charger system allows the transmitter and receiver to be charged at the same time.
- Over 3000 different identity codes to prevent conflicts with other e-collars.

### PRODUCT SAFETY AND HEALTH STATEMENTS

#### Safety for your dog

Studies conducted by animal health professionals at Dogtra Company's training facilities showed no adverse effects to the cardiovascular or nervous system of dogs from e-collar stimulation. These studies involved healthy dogs in a controlled environment.

Dogs should be in good health during any e-collar training. Dogtra e-collars are not intended for use on dogs weighing less than 12 pounds or under 6 months of age.

Skin irritation can occur from prolonged wearing of the stainless steel contact points on the training collar. Most dogs will exhibit some type of irritation (pressure necrosis) from prolonged contact of stainless steel contact points. This is why it states in your owner's manual:

#### Attention:

Avoid having the dog wear the collar with the contact points in the same place for more than two hours at a time. Leaving the contact points on the same spot for an extended period of time can cause skin irritation. If the dog is to wear the e-collar for long periods, occasionally reposition the collar so that the contact points are moved to a different spot on the dog's neck.

**Proper e-collar use**

**dogtra** e-collars are intended for the sole purpose of behavior modification of dogs. They are not intended for human use or use on other animals. Dogtra Company does not assume any liability for improper use of the Dogtra e-collar.

**Aggressive dogs**

**dogtra** does not recommend using the e-collar to correct dogs that are aggressive towards other dogs or people. In many such cases the dog will associate the stimulation with the other dog or individual and become even more aggressive. Dog aggression is best treated by a dog training specialist.

**Interference with other electronic devices**

Dogtra's industry-leading technology filtering system ensures minimal interference with other electronic devices (cellular phones, security systems, etc.). Our digital microprocessor offers thousands of unique codes to eliminate frequency match-up with other Dogtra e-collars.

**Inadvertent activation**

If the constant button is held down for 12 seconds or more the unit will automatically shut down. It will reactivate when the button is released.

**dogtra COLLAR**  
**PACKAGE CONTENTS**

- Transmitter
- Receiver
- Battery charger and splitter cable
- Owner's manual

## DESCRIPTION OF TRANSMITTER PARTS

*dogtrà 175NCP* transmitter

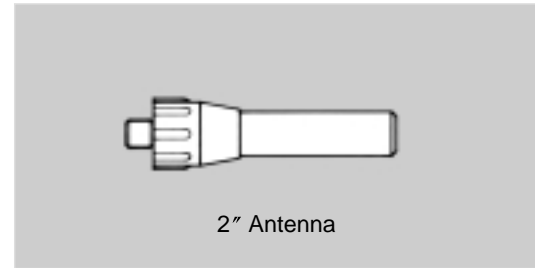
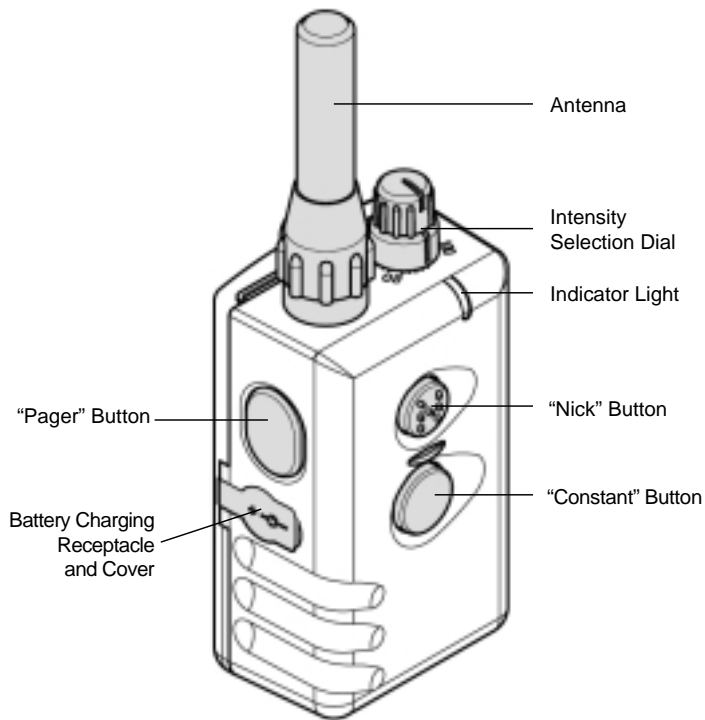

### Transmitter Antenna

A short 2" antenna is supplied with the *dogtrà 175NCP* transmitter.

The antenna should be screwed into the top of the transmitter to ensure that the signals are sent properly to the collar receiver and that maximum range is attained.

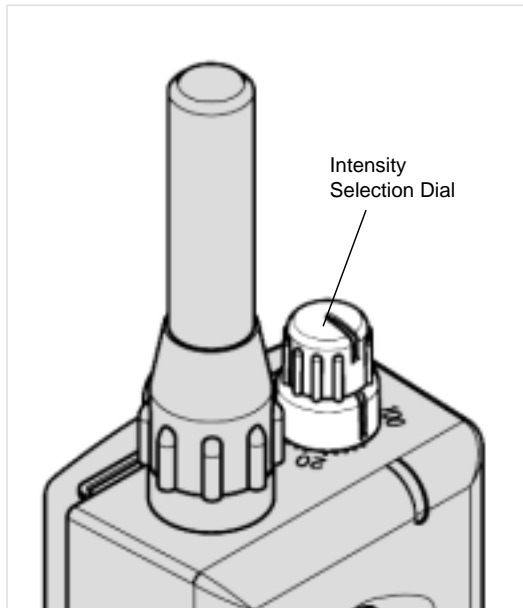

### **Intensity Selection Dial**

The intensity selection dial is located on the top of the transmitter: (0) being the lowest level and (100) being the highest.

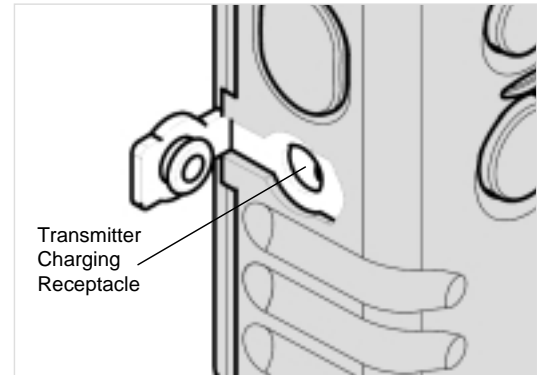

### **Transmitter Battery Charging Receptacle**

Located on the side of the transmitter, the receptacle is covered by a rubber plug. Insert one end of the battery charging cable into the receptacle to charge the battery. (See Battery Charging Procedure on page 21.)

After charging is completed, cover the receptacle with its rubber plug to make sure dirt or water does not get inside.

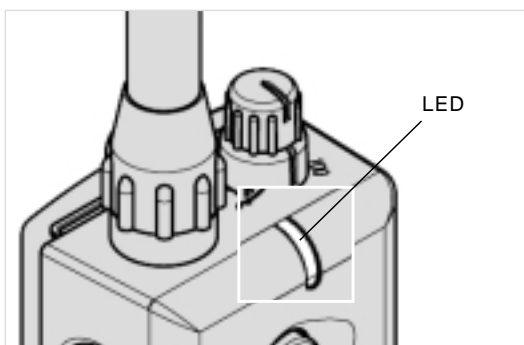

### Transmitter Indicator Light (LED window)

The transmitter indicator light is located near the intensity selection dial. When a button on the transmitter is pushed, the light comes on to indicate that the transmitter is being activated. The color of the light indicates the status of battery life. The LED glows green when the battery is fully charged and turns to amber when battery life is getting low. When the LED emits a blinking red light, the battery needs to be recharged.

**green** = full charge, **amber** = medium charge  
**red** = needs charge

## BUTTON FUNCTION

### *dogtra* 175 NCP

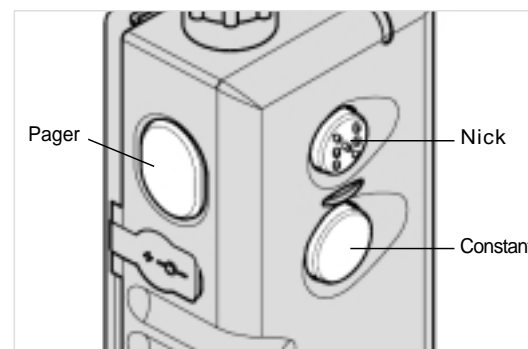

The transmitter for *dogtra* 175 NCP has three buttons (two on the face of the transmitter and one on the side).

**“Nick” Button**

When the “Nick” button is pushed the receiver emits a single, rapid pulse of electrical stimulation.

**“Constant” Button**

Pressing the “Constant” button gives continuous stimulation as long as the button is pushed, for up to twelve seconds. If the button is not released after twelve seconds, the stimulation will automatically turn off as a safety feature. The collar will be ready to be reactivated once the button has been released.

**“Pager” Button**

Pressing the “Pager” button on the side of the transmitter causes the collar to vibrate. This is a great way of communicating with your dog using non-electrical stimulation.

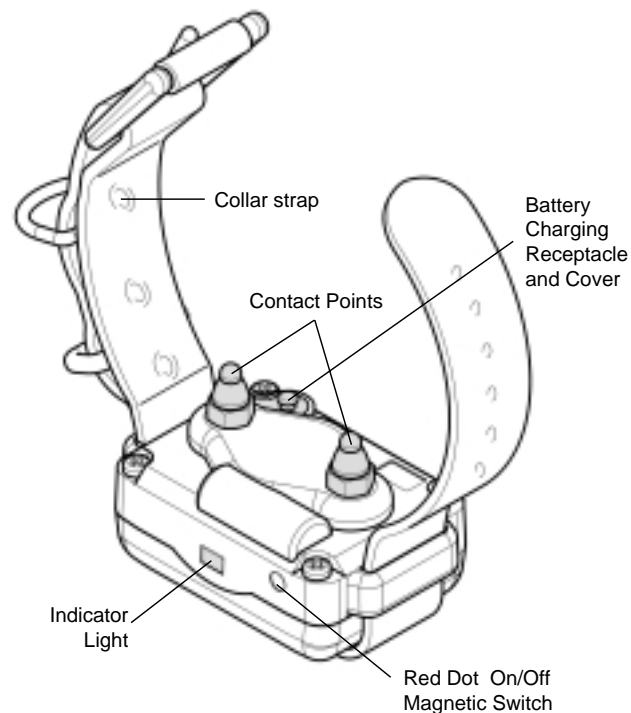
**DESCRIPTION OF  
COLLAR / RECEIVER PARTS*****dogtra 175 NCP* Collar**



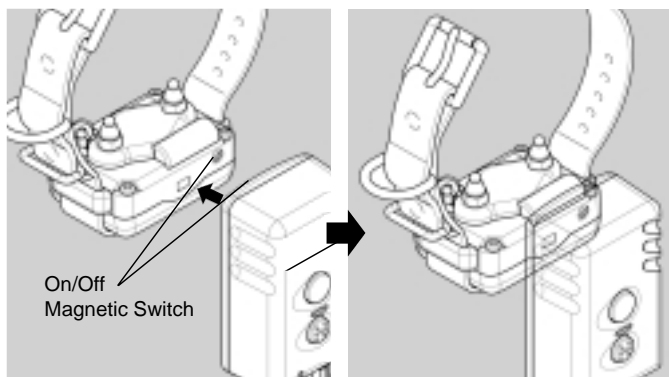

### On/Off Magnetic Switch

To activate the **dogtra 175NCP**, place the red dot on the back of the transmitter to the red dot on the collar receiver. Hold the two red dots together for a moment until the LED indicator light comes on.

To deactivate the **dogtra 175NCP** repeat the same procedure holding the two red dots together momentarily. The LED light will stop blinking, indicating that the unit is now shut off. To attain maximum battery life, deactivate the unit when not in use.

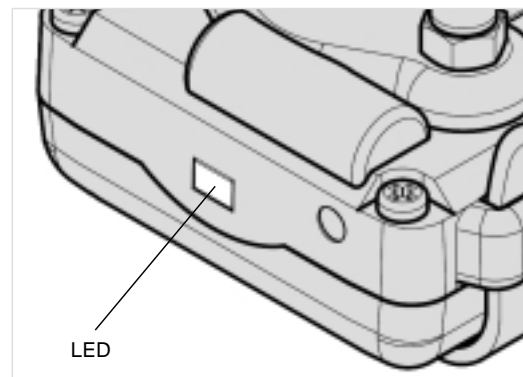

### Receiver Indicator Light (LED window)

Located on the front of the collar, the indicator light comes on and blinks once every 2 seconds after the collar is turned on. The color of the LED indicates the battery life of the receiver. (**green** = full charge, **amber** = medium charge, **red** = needs charge)

When the “Constant” button on the transmitter is pushed, the collar indicator light will glow steadily as long as you hold the button down, for up to twelve seconds. When the “Nick” button is pushed, the light comes on for a fraction of a second.

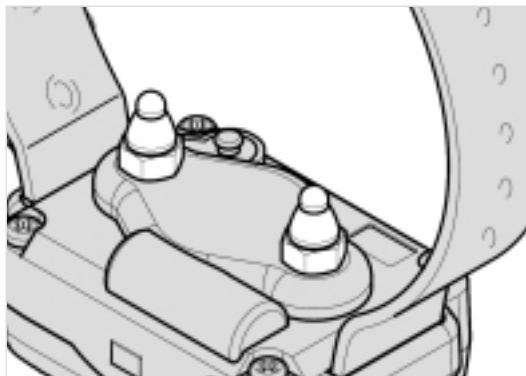

### Fitting the Collar on the Dog

The collar should be fitted so that the stainless steel contact points press firmly against the dog's skin.

A loose fit can allow the collar to move around on the dog's neck. When this happens the contact points may rub the skin and cause irritation. If the collar is too loose, electrical contact will be inconsistent and your corrections will be inconsistent also.

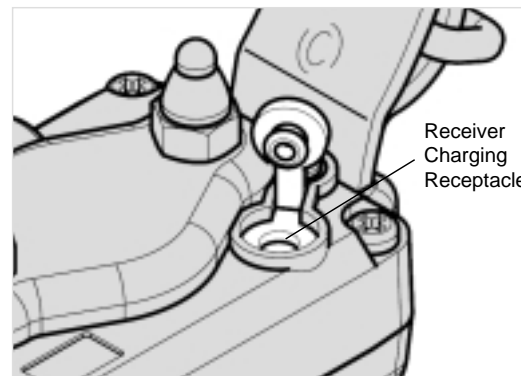

### Receiver Battery Charging Receptacle

On the inside of the collar, next to the collar strap, is a battery charging receptacle with a rubber cover plug.

### Internal Antenna

The *dogtra 175NCP* has a non-exposed antenna that is located inside the collar receiver.

### BATTERY CHARGER

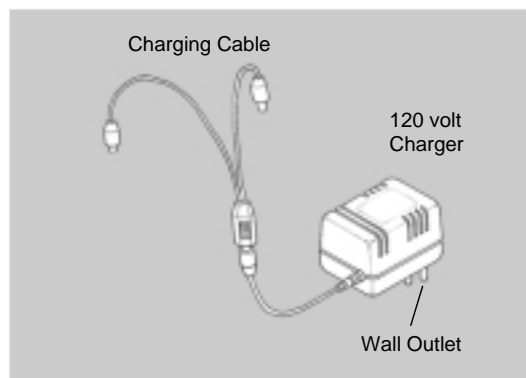

The battery charger and charging cables allow you to charge both the transmitter and receiver at the same time. The battery charger is designed for a 120-volt wall outlet. (European 230-volt AC chargers and 12-volt field charger for your automobile are also available.)

### CHARGING THE BATTERIES

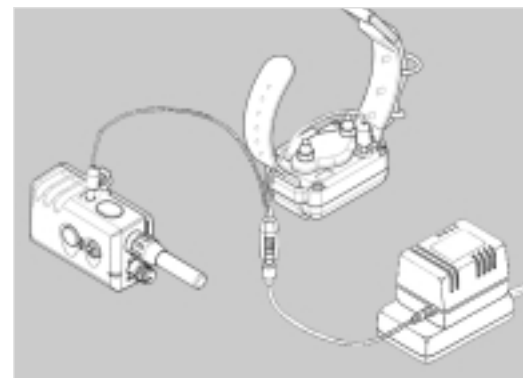

**dogtra** uses Ni-MH (Nickel-Metal-Hydride) batteries that do not set a memory and can be charged on a regular basis without harm to the battery. There is no need to completely drain the batteries between charges. However, doing so will help to extend the overall lifetime of the batteries.

1. Charge the batteries for 14 hours before using the collar for the first time.

2. Do not charge the batteries near any flammable substances.
3. Fully charge the batteries for 14 hours if the unit is to be stored without use for a period of a month or more.
4. Recharge the unit if:
  - the indicator light on the collar is emitting a red color
  - the indicator light on the transmitter or receiver will not come on
  - the indicator light on the transmitter or receiver comes on momentarily, but will not stay on when the “Constant” button is pushed.

### Battery Charging Procedure

1. Attach the charging cables to both the transmitter and receiver(s), as shown on page 19.
2. Plug the charger into a 120-volt wall outlet or, if using the accessory field charger, plug into a cigarette lighter. (Use a 230-volt European charger for Europe.) When properly plugged in, all indicator lights should glow red.

The receiver automatically turns off when you insert the charging cable into the battery-charging receptacle on the receiver.
3. After charging, cover the battery charging receptacles with the rubber plugs on the transmitter and receiver.
4. The battery is fully charged with a 14-hour charge. The lights will stay red during the charging process. They DO NOT turn green when fully charged. Charging the batteries for more than 14 hours at one time will not extend battery life.

## TESTING YOUR *dogtra* 175 NCP COLLAR

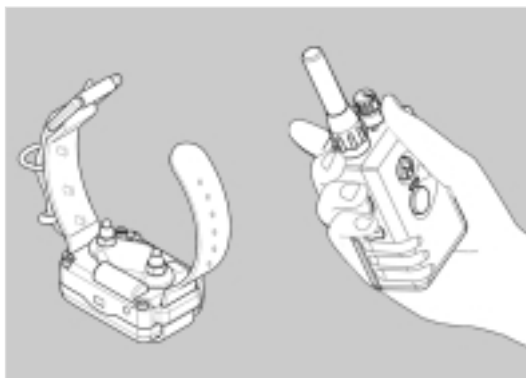

1. To activate the *dogtra* 175 NCP, place the red dot on the back of the transmitter to the red dot on the collar. Hold the two red dots together for a moment until the LED indicator light comes on. The indicator light will blink every two seconds showing the unit is charged and ready to use. (If the indicator light emits a red color, the batteries need to be charged.)

2. Turn the intensity level on the transmitter up to the maximum level (100) and press the Nick button. The indicator light(LED) on the collar receiver will light briefly as you push the button. Pressing the Constant button will light the indicator for as long as you hold the button down, up to twelve seconds.
3. As a safety feature, the *dogtra* 175 NCP will automatically shut off stimulation if the constant button is depressed for twelve seconds or longer. The button will be ready to be reactivated once the button is released.

## OPERATING INSTRUCTIONS

### Fitting the Collar

The collar strap should be adjusted so that the contact points are held firmly against the dog's skin. If the collar is too loose, irritation may result from the contact points rubbing against the skin.

If the dog has a heavy coat, move the receiver up and down to work the contact points down into the coat.

### ATTENTION!

**Avoid having the dog wear the collar with the contact points in the same place for more than two hours at a time. Leaving the points on the same spot for extended periods of time can cause skin irritation. If the dog is to wear the e-collar for long periods, occasionally reposition the collar so that the contact points are placed in a different spot on the dog's neck.**

### Intensity Selection

To select the intensity level, start on the zero (0) setting. Gradually increase the level until you get a response from the dog that would be equivalent to a quick pull or jerk with a leash.

Remember that you will need to adjust the setting (upward or downward) as the dog's attitude changes, especially during times of increased excitement or distraction.

Prolonged use of the Pager (12 seconds or longer) will drain the batteries more quickly.

### Maintenance

The receiver and collar strap should be cleaned periodically with detergent and water to prevent malfunction.

Always clean and rinse the collar thoroughly with tap water after use in salt water. Be sure the charging receptacle is completely dry before inserting the battery charger into the transmitter or receiver.

### Reception

The **dogtra 175 NCP** e-collar has a range of 400+ yards. Depending on the way you use your transmitter, the transmitting range may vary. Hold the transmitter away from your body and avoid touching the antenna to get the greatest range.

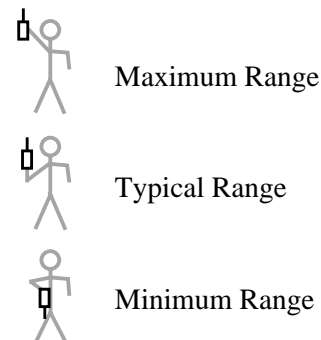

If your finger touches the antenna near the dial on the top of the transmitter, the actual range may be reduced. Additional environmental factors may also affect the range of your unit.

## ACCESSORIES

The following items may be purchased separately:

### **European Charger**

Designed for use with 230V AC electrical outlets in Europe.

### **Field Auto Charger**

Designed for use with the 12-volt cigarette lighter in your car.

## WARRANTY AND REPAIR INFORMATION

**Dogtra Company** provides the original purchaser a **LIMITED LIFETIME WARRANTY** for the 175NCP on parts (excluding batteries) from the date of the original purchase. Labor is covered for two years after purchase. Once the labor warranty has expired, all repairs will incur a variable labor charge depending on the extent of work required.

### **To Qualify for the Limited Lifetime Warranty:**

The limited lifetime warranty applies to units purchased after Dec. 31, 2005. Fill out the warranty registration card that came with your Dogtra unit and mail it in along with a copy of your receipt within 30 days of purchase. Or, you can register your product online at [www.dogtra.com](http://www.dogtra.com).



### **Not Covered Under Warranty:**

If product registration is not completed within 30 days of purchase and/or the product is resold, the warranty will become void and all repairs will be subject to applicable labor fees.

**Dogtra** DOES NOT replace defective units or provide refunds after 30 days from date of purchase.

**Dogtra's** warranty DOES NOT cover repairs or replacement due to misuse, improper maintenance or lost units. Any water damage on models that are not waterproof will not be covered. All replacement costs for either the transmitter or receiver is the owner's responsibility.

The Limited Lifetime Warranty will expire (5) years from the date a unit is discontinued in production by Dogtra Company.

\* Batteries, or the labor to replace them, are NOT covered under the warranty after the first year.

The warranty is void if the unit has been altered or an unauthorized person has attempted repair work.

### **Procedure for Repair Work:**

Return shipping for warranty work is the owner's responsibility. The cost for shipping (via regular ground service) back to the customer is covered by Dogtra Co. within the continental United States. Any expedited shipping service will be at the owner's expense. Dogtra is not responsible for loss of training time or inconvenience while the unit is in our warehouse for repair work. Dogtra does not provide loaner units or any form of compensation during the repair period.

A copy of the sales receipt showing purchase date is required before warranty work is begun.

Write a note briefly explaining the problem and include your name, address, city/state/zip code, daytime phone number and evening phone

## REPAIR

---

number. Or, you can visit our web site at [www.dogtra.com](http://www.dogtra.com) to fill out a Service Request Form. If repair costs are not covered under warranty, we will call you for credit card information once the work has been completed. For any questions concerning your Dogtra products call us Toll Free at 1-888-811-9111, Pacific Time.

Send repair units to:

**Dogtra Company**

1250 E. 223rd Street, Suite 119  
Carson, CA 90745